

- 1
- 2
- 3
- 4
- 5
- 6
- 7
- 8
- 9
- 10
- 11
- 12
- 13
- 14
- 15

MATERIAL

Glass-fibre reinforced polyamide based (PA) technopolymer, black colour, matte finish.

STANDARD EXECUTION

Nickel-plated brass boss with threaded pass-through hole.



NDX.Q - 20 - 25 - 30 - 35 - 40

NDX.Q - 50 - 60

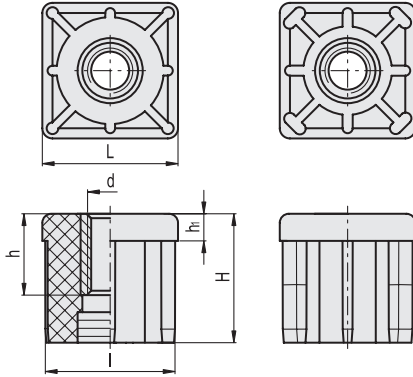

Conversion Table
1 mm = 0.039 inch

METRIC

Code	Description	L	d	h	H	h1	l	Tube external diameter	Tube internal diameter	Tube thickness	Max. static load* [N]	Δ
320011	NDX.Q-20x1.5-M8	20	M8	10	23	5	17	20	17	1.5	4000	13
320016	NDX.Q-20x2-M8	20	M8	10	23	5	16	20	16	2	4000	13
320021	NDX.Q-25x1.5-M8	25	M8	10	26	6	22	25	22	1.5	4500	20
320022	NDX.Q-25x1.5-M10	25	M10	10	26	6	22	25	22	1.5	4500	20
320023	NDX.Q-25x1.5-M12	25	M12	10	26	6	22	25	22	1.5	4500	20
320026	NDX.Q-25x2-M8	25	M8	10	26	6	21	25	21	2	4500	20
320027	NDX.Q-25x2-M10	25	M10	10	26	6	21	25	21	2	4500	20
320031	NDX.Q-30x1.5-M8	30	M8	10	31	6	27	30	27	1.5	4500	28
320032	NDX.Q-30x1.5-M10	30	M10	10	31	6	27	30	27	1.5	4500	28
320033	NDX.Q-30x1.5-M12	30	M12	10	31	6	27	30	27	1.5	4500	28
320034	NDX.Q-30x1.5-M14	30	M14	15	31	6	27	30	27	1.5	4500	30
320035	NDX.Q-30x1.5-M16	30	M16	15	31	6	27	30	27	1.5	4500	30
320041	NDX.Q-30x2.0-M8	30	M8	10	31	6	26	30	26	2	4500	28
320042	NDX.Q-30x2.0-M10	30	M10	10	31	6	26	30	26	2	4500	28
320043	NDX.Q-30x2.0-M12	30	M12	10	31	6	26	30	26	2	4500	28
320044	NDX.Q-30x2.0-M14	30	M14	15	31	6	26	30	26	2	4500	30
320045	NDX.Q-30x2.0-M16	30	M16	15	31	6	26	30	26	2	4500	30
320051	NDX.Q-35x1.5-M8	35	M8	10	38	8	32	35	32	1.5	6000	40
320052	NDX.Q-35x1.5-M10	35	M10	10	38	8	32	35	32	1.5	6000	40
320053	NDX.Q-35x1.5-M12	35	M12	10	38	8	32	35	32	1.5	6000	40
320054	NDX.Q-35x1.5-M14	35	M14	15	38	8	32	35	32	1.5	6000	42
320055	NDX.Q-35x1.5-M16	35	M16	15	38	8	32	35	32	1.5	6000	42
320056	NDX.Q-35x1.5-M20	35	M20	20	38	8	32	35	32	1.5	6000	41
320061	NDX.Q-35x2-M8	35	M8	10	38	8	31	35	31	2	6000	40
320062	NDX.Q-35x2-M10	35	M10	10	38	8	31	35	31	2	6000	40
320063	NDX.Q-35x2-M12	35	M12	10	38	8	31	35	31	2	6000	40
320064	NDX.Q-35x2-M14	35	M14	15	38	8	31	35	31	2	6000	42
320065	NDX.Q-35x2-M16	35	M16	15	38	8	31	35	31	2	6000	42
320066	NDX.Q-35x2-M20	35	M20	20	38	8	31	35	31	2	6000	40

* The max static load is the value above which the load applied to the element may cause some plastic material breakage, in particular conditions of use. Obviously, a factor that takes into consideration the importance and the safety level of the specific application must be applied to this value.

Levelling elements and supports

Code	Description	L	d	h	H	h1	l	Tube external diameter	Tube internal diameter	Tube thickness	Max. static load* [N]	
320071	NDX.Q-40x1.2-M8	40	M8	10	38	8	37.6	40	37.6	1.2	6000	47
320072	NDX.Q-40x1.2-M10	40	M10	10	38	8	37.6	40	37.6	1.2	6000	47
320073	NDX.Q-40x1.2-M12	40	M12	10	38	8	37.6	40	37.6	1.2	6000	47
320074	NDX.Q-40x1.2-M14	40	M14	15	38	8	37.6	40	37.6	1.2	6000	49
320075	NDX.Q-40x1.2-M16	40	M16	15	38	8	37.6	40	37.6	1.2	6000	49
320076	NDX.Q-40x1.2-M20	40	M20	20	38	8	37.6	40	37.6	1.2	8000	48
320081	NDX.Q-40x1.5-M8	40	M8	10	38	8	37	40	37	1.5	6000	47
320082	NDX.Q-40x1.5-M10	40	M10	10	38	8	37	40	37	1.5	6000	47
320083	NDX.Q-40x1.5-M12	40	M12	10	38	8	37	40	37	1.5	6000	47
320084	NDX.Q-40x1.5-M14	40	M14	15	38	8	37	40	37	1.5	6000	49
320085	NDX.Q-40x1.5-M16	40	M16	15	38	8	37	40	37	1.5	6000	49
320086	NDX.Q-40x1.5-M20	40	M20	20	38	8	37	40	37	1.5	8000	48
320091	NDX.Q-40x2-M8	40	M8	10	38	8	36	40	36	2	6000	47
320092	NDX.Q-40x2-M10	40	M10	10	38	8	36	40	36	2	6000	47
320093	NDX.Q-40x2-M12	40	M12	10	38	8	36	40	36	2	6000	47
320094	NDX.Q-40x2-M14	40	M14	15	38	8	36	40	36	2	6000	49
320095	NDX.Q-40x2-M16	40	M16	15	38	8	36	40	36	2	6000	49
320096	NDX.Q-40x2-M20	40	M20	20	38	8	36	40	36	2	8000	48
320101	NDX.Q-40x2.5-M8	40	M8	10	38	8	35	40	35	2.5	6000	47
320102	NDX.Q-40x2.5-M10	40	M10	10	38	8	35	40	35	2.5	6000	47
320103	NDX.Q-40x2.5-M12	40	M12	10	38	8	35	40	35	2.5	6000	47
320104	NDX.Q-40x2.5-M14	40	M14	15	38	8	35	40	35	2.5	6000	49
320105	NDX.Q-40x2.5-M16	40	M16	15	38	8	35	40	35	2.5	6000	49
320106	NDX.Q-40x2.5-M20	40	M20	20	38	8	35	40	35	2.5	8000	50
320098	NDX.Q-40x3-M10	40	M10	10	38	8	34	40	34	3	6000	49
320099	NDX.Q-40x3-M12	40	M12	10	38	8	34	40	34	3	6000	48
320108	NDX.Q-45x3-M12	45	M12	10	38	8	39	45	39	3	6000	47
320109	NDX.Q-45x3-M16	45	M16	15	38	8	39	45	39	3	6000	46
320111	NDX.Q-50x1.2-M8	50	M8	10	45	10	47.6	50	47.6	1.2	6000	72
320112	NDX.Q-50x1.2-M10	50	M10	10	45	10	47.6	50	47.6	1.2	6000	72
320113	NDX.Q-50x1.2-M12	50	M12	10	45	10	47.6	50	47.6	1.2	6000	72
320114	NDX.Q-50x1.2-M14	50	M14	15	45	10	47.6	50	47.6	1.2	6000	74
320115	NDX.Q-50x1.2-M16	50	M16	15	45	10	47.6	50	47.6	1.2	6000	74
320116	NDX.Q-50x1.2-M20	50	M20	20	45	10	47.6	50	47.6	1.2	8500	75
320121	NDX.Q-50x1.5-M8	50	M8	10	45	10	47	50	47	1.5	6000	72
320122	NDX.Q-50x1.5-M10	50	M10	10	45	10	47	50	47	1.5	6000	72
320123	NDX.Q-50x1.5-M12	50	M12	10	45	10	47	50	47	1.5	6000	72
320124	NDX.Q-50x1.5-M14	50	M14	15	45	10	47	50	47	1.5	6000	74
320125	NDX.Q-50x1.5-M16	50	M16	15	45	10	47	50	47	1.5	6000	74
320126	NDX.Q-50x1.5-M20	50	M20	20	45	10	47	50	47	1.5	8500	75
320131	NDX.Q-50x2-M8	50	M8	10	45	10	46	50	46	2	6000	72
320132	NDX.Q-50x2-M10	50	M10	10	45	10	46	50	46	2	6000	72
320133	NDX.Q-50x2-M12	50	M12	10	45	10	46	50	46	2	6000	72
320134	NDX.Q-50x2-M14	50	M14	15	45	10	46	50	46	2	6000	74
320135	NDX.Q-50x2-M16	50	M16	15	45	10	46	50	46	2	6000	74
320136	NDX.Q-50x2-M20	50	M20	20	45	10	46	50	46	2	8500	75
320141	NDX.Q-50x2.5-M8	50	M8	10	45	10	45	50	45	2.5	6000	72
320142	NDX.Q-50x2.5-M10	50	M10	10	45	10	45	50	45	2.5	6000	72
320143	NDX.Q-50x2.5-M12	50	M12	10	45	10	45	50	45	2.5	6000	72
320144	NDX.Q-50x2.5-M14	50	M14	15	45	10	45	50	45	2.5	6000	74
320145	NDX.Q-50x2.5-M16	50	M16	15	45	10	45	50	45	2.5	6000	74
320146	NDX.Q-50x2.5-M20	50	M20	20	45	10	45	50	45	2.5	8500	74
320152	NDX.Q-50x3.0-M10	50	M10	10	45	10	44	50	44	3	6000	72
320153	NDX.Q-50x3.0-M12	50	M12	10	45	10	44	50	44	3	6000	72
320154	NDX.Q-50x3.0-M14	50	M14	15	45	10	44	50	44	3	6000	74
320155	NDX.Q-50x3.0-M16	50	M16	15	45	10	44	50	44	3	6000	74
320156	NDX.Q-50x3.0-M20	50	M20	20	45	10	44	50	44	3	8500	75
320162	NDX.Q-60x2.0-M10	60	M10	10	45	10	56	60	56	2	6000	98
320163	NDX.Q-60x2.0-M12	60	M12	10	45	10	56	60	56	2	6000	98
320164	NDX.Q-60x2.0-M14	60	M14	15	45	10	56	60	56	2	6000	98
320165	NDX.Q-60x2.0-M16	60	M16	15	45	10	56	60	56	2	6000	97
320166	NDX.Q-60x2.0-M20	60	M20	20	45	10	56	60	56	2	8500	97
320172	NDX.Q-60x3.0-M10	60	M10	10	45	10	54	60	54	3	6000	98
320173	NDX.Q-60x3.0-M12	60	M12	10	45	10	54	60	54	3	6000	98
320174	NDX.Q-60x3.0-M14	60	M14	15	45	10	54	60	54	3	6000	98
320175	NDX.Q-60x3.0-M16	60	M16	15	45	10	54	60	54	3	6000	97
320176	NDX.Q-60x3.0-M20	60	M20	20	45	10	54	60	54	3	8500	97

* The max static load is the value above which the load applied to the element may cause some plastic material breakage, in particular conditions of use. Obviously, a factor that takes into consideration the importance and the safety level of the specific application must be applied to this value.

